

ROWLAND WATER DISTRICT

INSTALLATION SPECIFICATION FOR REDUCED PRESSURE PRINCIPLE BACKFLOW PREVENTION ASSEMBLY

ASSEMBLY TYPE AND LOCATION REQUIRES APPROVAL BY
ROWLAND WATER DISTRICT PRIOR TO INSTALLATION

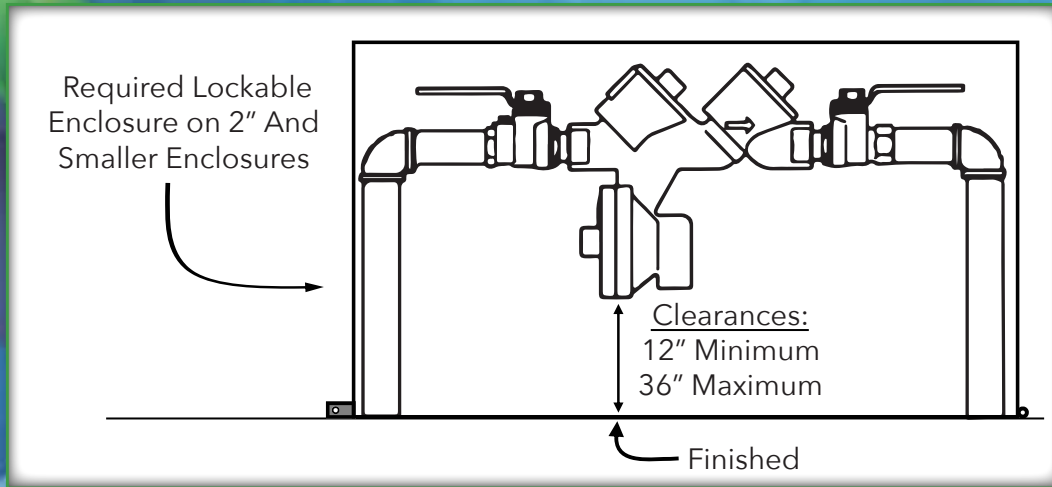

1. The assembly shall be located as close as practical to the water meter within customer's property. Allow sufficient room between assembly and property line for installation of lockable enclosure.
2. Lockable enclosure required on assemblies 2" and smaller. Enclosure must meet clearance, access and drainage requirements.
3. There shall be no valve, tap, tee or service connection between the meter and the assembly.
4. Minimum of 12" side clearance for test cocks, and a minimum 12" to a maximum of 36" clearance from bottom of relief valve to ground.
5. Must be accessible for testing and repair.
6. The assembly must be tested by a certified backflow prevention tester within 30 days of the install date and annually thereafter.
7. Any deviation from the method described above must receive written approval from the district prior to installation.

